

**PROPER USE GUIDELINES**

Cumulative Trauma Disorders can result from the prolonged use of manually powered hand tools. Hand tools are intended for occasional use and low volume applications. A wide selection of powered application equipment for extended-use, production operations is available.

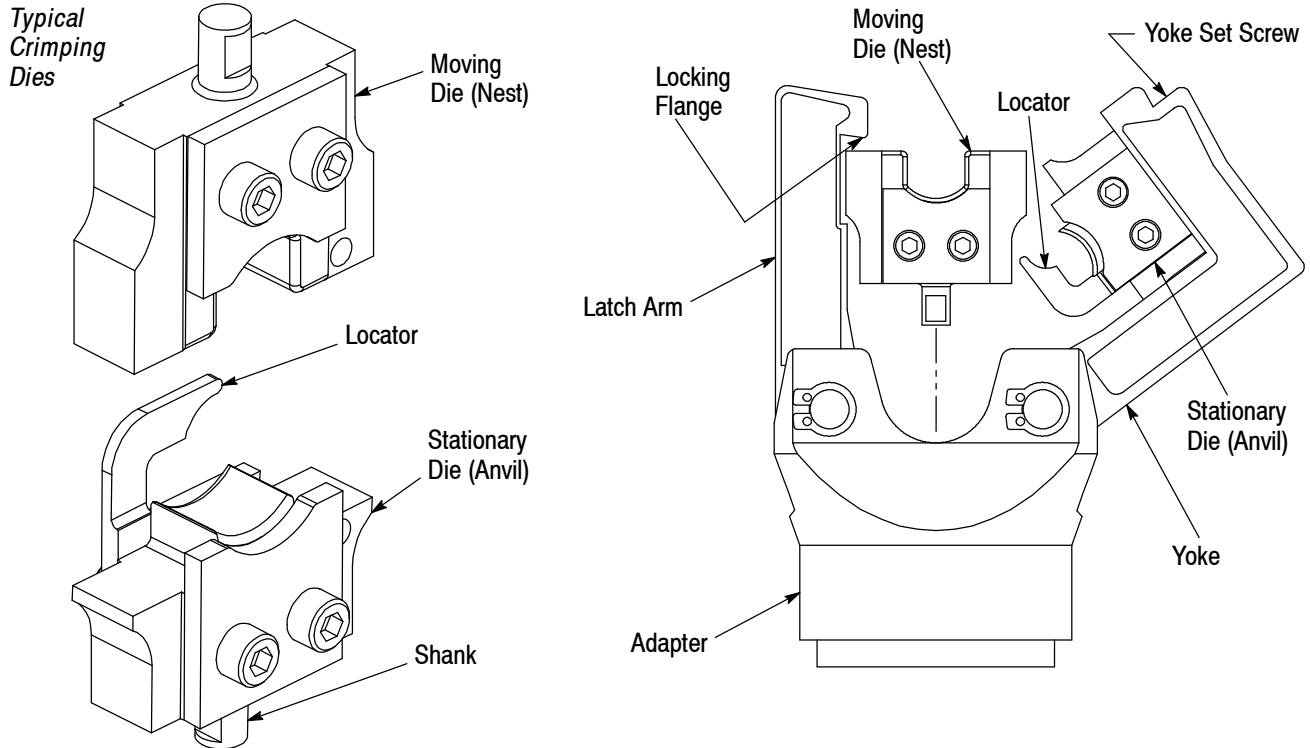

| CRIMPING DIE |                | WIRE SIZE (AWG) |
|--------------|----------------|-----------------|
| PART NUMBER  | COLOR CODE DOT |                 |
| 1901006-1    | Red            | 8               |
| 1901007-1    | Blue           | 6               |

Figure 1

**1. INTRODUCTION**

Crimping Dies 1901006-1 and 1901007-1 are used with Battery Powered Hand Tool 1901343-1, -2, -3, and -4 (Customer Manual 409-10070) and Battery Powered Hand Tool 2031404-1, -11, -21, -31, and -41 (Customer Manual 409-10103). The dies crimp TERMINYL Terminals and Splices onto wire sizes 8 through 6 AWG, TERMINYL Splices with step-down adapters onto wire sizes 16-14 through 6 AWG, and PLASTI-GRIP Terminals and Splices onto wire sizes 8 through 6 AWG. Refer to Figure 1 to ensure compatibility of crimping die part number, color code dot, and wire size.

**NOTE**

*Dimensions in this document are in millimeters [with inches in brackets]. Figures and Illustrations are for reference only and are not drawn to scale.*

**2. DESCRIPTION**

Each crimping die consists of a stationary die (nest) and a moving die (anvil). The stationary die features a locator. Each die contains a color code dot that matches the color code of the terminal and splice. When mated, the dies form a crimping chamber.

**3. DIE INSTALLATION AND REMOVAL**

**3.1. Die Installation**

1. Pivot the latch arm away from the yoke to open the crimp head. See Figure 1.
2. Loosen the set screw in the yoke.
3. Insert the shank of the stationary die into the yoke, and tighten the set screw.
4. Extend the ram until the ram set screw is visible.

5. Loosen the set screw in the ram.
6. Insert the shank of the moving die into the ram and tighten the set screw.

**CAUTION** To avoid damage to the dies, be sure that the moving and stationary dies are properly oriented.

7. Activate the tool to allow the ram to return to the “down” position.
8. Pivot the yoke and latch arm toward each other until the locking flange secures the latch arm to the yoke.

**CAUTION** Always make sure the yoke and latching arm are secured by the locking flange before cycling the tool.

### 3.2. Die Removal

1. Pivot the latch arm away from the yoke to open the head.
2. Loosen the set screw in the yoke and remove the stationary die.
3. Extend the ram until the ram set screw is visible.
4. Loosen the set screw in the ram. Remove the moving die.

## 4. CRIMPING PROCEDURE

### 4.1. Crimping Terminals

**DANGER** Avoid personal injury. When operating the tool, exercise caution while holding terminals or wire near the crimping area.

1. Strip wire to the dimensions listed in Figure 2. Do not nick or cut the wire strands.

2. Select the proper color-coded terminal for the wire size. The wire size stamped on the terminal tongue and on the crimping die must match the wire size selected.

3. Insert stripped wire fully into terminal wire barrel. The end of the conductor must not protrude more than 1.60 mm [.063 in.] beyond the edge of the wire barrel.

**NOTE** Do NOT turn or twist the wire or terminal during insertion.

4. Pivot the latch arm away from the yoke to open the head.
5. Place the terminal in the stationary die with the edge of the wire barrel resting against the locator and the bottom of the terminal tongue facing the stationary die. See Figure 3.

6. Holding the terminal in place, pivot the yoke and latch arm toward each other until the locking flange secures the latch arm to the yoke.

**CAUTION** Always make sure the yoke and latching arm are secured by the locking flange before cycling the tool.

7. Holding the wire in place, activate the tool to complete the crimp.

8. When the crimp is completed, pivot the latch arm away from the yoke to open the head and remove the terminal.

**NOTE** If terminal sticks in die after crimping, apply a rocking action to the terminal to remove it from the die. Wipe light oil on the dies to prevent sticking, or use spray dry lubricant.

9. Inspect the crimp according to Section 5.

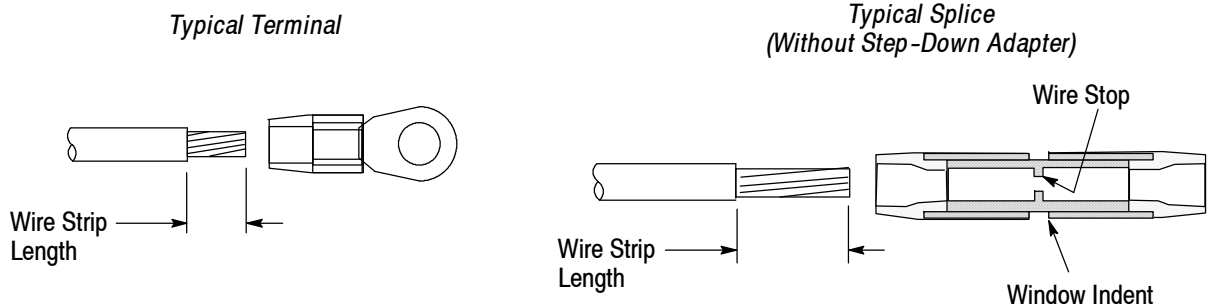

| WIRE SIZE (AWG) | WIRE STRIP LENGTH            |                         |                                 |
|-----------------|------------------------------|-------------------------|---------------------------------|
|                 | TERMINYL TERMINAL AND SPLICE |                         | PLASTI-GRIP TERMINAL AND SPLICE |
|                 | TERMINAL                     | SPLICE                  |                                 |
| 8               | 7.96-9.53 [.313-.375]        | 15.48-17.07 [.609-.672] | 11.51-12.29 [.453-.484]         |
| 6               | 11.18-12.70 [.440-.500]      | 19.45-20.24 [.766-.797] | 15.47-16.26 [.609-.640]         |

Figure 2

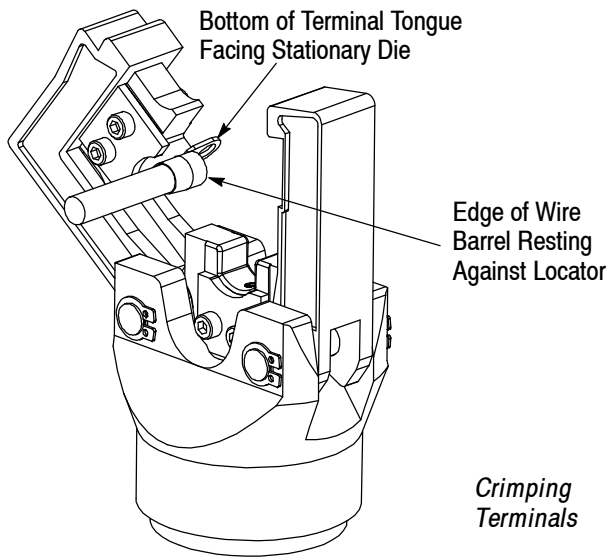

Figure 3

#### 4.2. Crimping Splices Without Step-Down Adapter

**DANGER** Avoid personal injury. When operating the tool, exercise caution while holding splice or wire near the crimping area.

1. Strip wires to the dimensions listed in Figure 2. Do not nick or cut the wire strands.
2. Select the proper color-coded splice for the wire size. The wire size stamped on the splice and on the crimping die must match the wire size selected.
3. Insert the stripped wire into the wire barrel of the end of the splice to be crimped until the wire bottoms against the wire stop within the splice.
4. Pivot the latch arm away from the yoke to open the head.
5. Place the splice in the stationary die. Grasp the end of the splice to be crimped and point the opposite end toward the top of the head yoke at approximately a 30° angle. Rotate the end of the splice to be crimped into the die. Position the edge of the window indent against the locator. Refer to Figure 4.
6. Holding the splice in place, pivot the yoke and latch arm toward each other until the locking flange secures the latch arm to the yoke.

**CAUTION** Always make sure the yoke and latching arm are secured by the locking flange before cycling the tool.

7. Holding wire in place, activate the tool to complete first wire barrel crimp.
8. When crimp is completed, pivot the latch arm away from the yoke to open the head and remove the splice.

**NOTE** If splice sticks in die after crimping, apply a rocking action to the splice to remove it from the die. Wipe light oil on dies to reduce sticking, or use spray dry lubricant.

9. To crimp the other half of splice, reposition uncrimped end of splice in the stationary die and follow the same procedure used to crimp the first half of splice.
10. Inspect the crimp according to Section 5.

#### Crimping Splices With or Without Step-Down Adapter

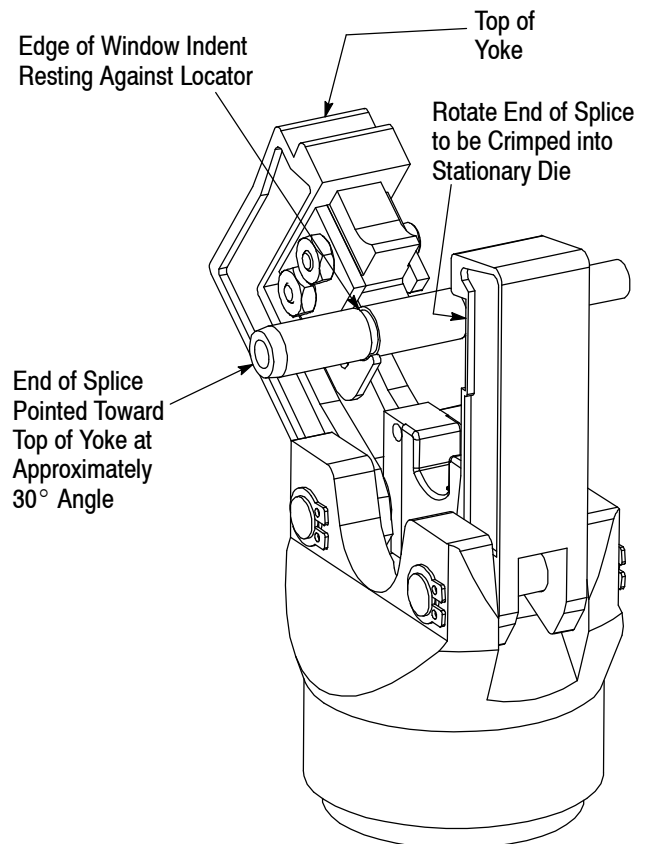

Figure 4

#### 4.3. Crimping Splices With Step-Down Adapter

**DANGER** Avoid personal injury. When operating the tool, exercise caution while holding splice or wire near the crimping area.

1. Strip wires to the dimensions listed in Figure 2. Do not nick or cut the wire strands.
2. Select the proper splice, adapter, and crimping die for the wire size. See Figure 5. Note that the end of the splice containing the adapter has a different color code. Use the crimping die for the larger wire size to crimp both ends of the splice. For example, use Crimping Die 1901006-1 (for wire size 8 AWG) to crimp both ends of the splice with step-down adapter for stepping down from wire size 8 to 16-14 AWG.

Splices with Step-Down Adapter

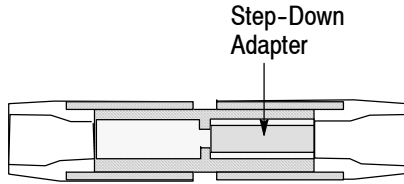

| WIRE SIZE (AWG) STEP | CRIMPING DIE | DIE AND SPLICE COLOR CODE | STEP-DOWN ADAPTER COLOR CODE |
|----------------------|--------------|---------------------------|------------------------------|
| 8 to 16-14           | 1901006-1    | Red                       | Blue                         |
| 8 to 12-10           | 1901006-1    | Red                       | Yellow                       |
| 6 to 8               | 1901007-1    | Blue                      | Red                          |

Figure 5

3. Insert stripped wire into the wire barrel of the end of the splice to be crimped until the wire bottoms against the wire stop within the splice. Refer to Figure 2.
4. Pivot the latch arm away from the yoke to open the head.
5. Place the splice in the stationary die. Grasp the end of the splice to be crimped and point the opposite end toward the top of the head yoke at approximately a 30° angle. Rotate the end of the splice to be crimped into the die. Position the edge of the window indent against the locator. Refer to Figure 4.
6. Holding the splice in place, pivot the yoke and latch arm toward each other until the locking flange secures the latch arm to the yoke.

**CAUTION** Always make sure the yoke and latching arm are secured by the locking flange before cycling the tool.

7. Holding the wire in place, active the tool to complete the first wire barrel crimp.
8. When crimp is complete, pivot the latch arm away from the yoke to open the head and remove the splice.

**NOTE** If splice sticks in die after crimping, apply a rocking action to the splice to remove it from the die. Wipe light oil on dies to reduce sticking, or use spray dry lubricant.

9. To crimp the other half of splice, reposition uncrimped end of splice in the stationary die and follow the same procedure used to crimp the first half of splice.

10. Inspect the crimp according to Section 5.

4.4. Crimping PLASTI-GRIP Butt Splices

**DANGER** Avoid personal injury. When operating the tool, exercise caution while holding butt splices or wire near the crimping area.

1. Strip wires to the dimensions listed in Figure 2. Do not nick or cut the wire strands.
2. Select the proper color-coded butt splice for the wire size. The wire size stamped on the butt splice and on the crimping die must match the wire size selected.
3. Pivot the latch arm away from the yoke to open the head. Remove the stationary die from the yoke, then remove the locator from the stationary die. Re-assemble the stationary die onto the yoke.

**CAUTION** To avoid damage to the dies, be sure that the stationary die is properly oriented with the moving die.

4. Insert the stripped wire into the wire barrel of the end of the butt splice to be crimped until the wire bottoms against the wire stop within the splice.
5. Place the butt splice in the stationary die with the wire barrel of the end of the splice to be crimped centered over the crimping chamber. See Figure 6.
6. Holding the butt splice in place, pivot the yoke and latch arm toward each other until the locking flange secures the latch arm to the yoke.

**CAUTION** Always make sure the yoke and latching arm are secured by the locking flange before cycling the tool.

Crimping Butt Splices

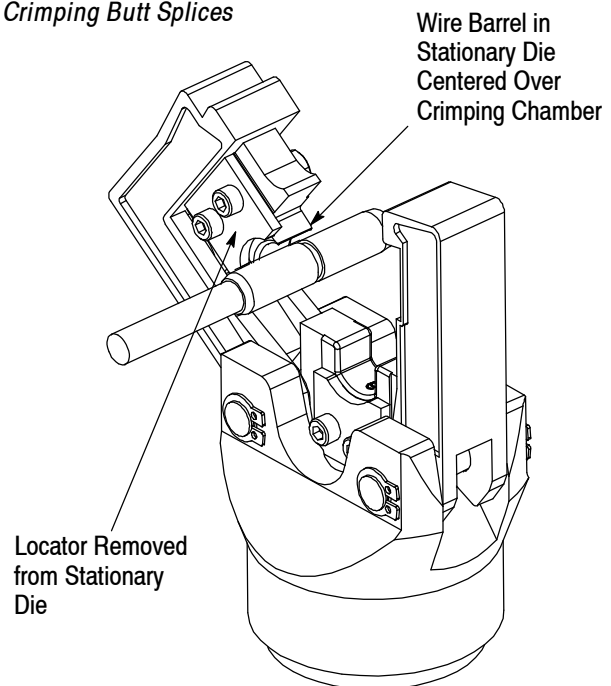

Figure 6

7. Holding the wire in place, activate the tool to complete the first wire barrel crimp.
8. When crimp is completed, pivot the latch arm away from the yoke to open the head and remove the butt splice.

**NOTE**

*If butt splice sticks in die after crimping, apply a rocking action to the butt splice to remove it from the die. Wipe light oil on dies to reduce sticking, or use spray dry lubricant.*

**ACCEPT**

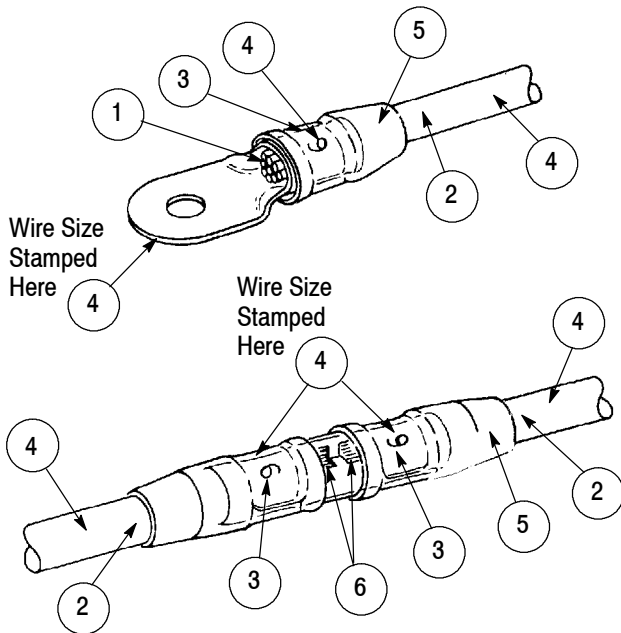

- ① End of wire conductor is flush with or extends beyond edge of terminal wire barrel a maximum of 1.60 [.063].
- ② Wire fully inserted.
- ③ Crimp centered on wire barrel.
- ④ Wire size is the same as wire size stamped on terminal tongue, splice body, and wire barrel.
- ⑤ Proper color code, wire size, and tooling combination used.
- ⑥ Wire conductors butted against wire stop, or flush with or extended slightly beyond edge of splice wire barrel.

**REJECT**

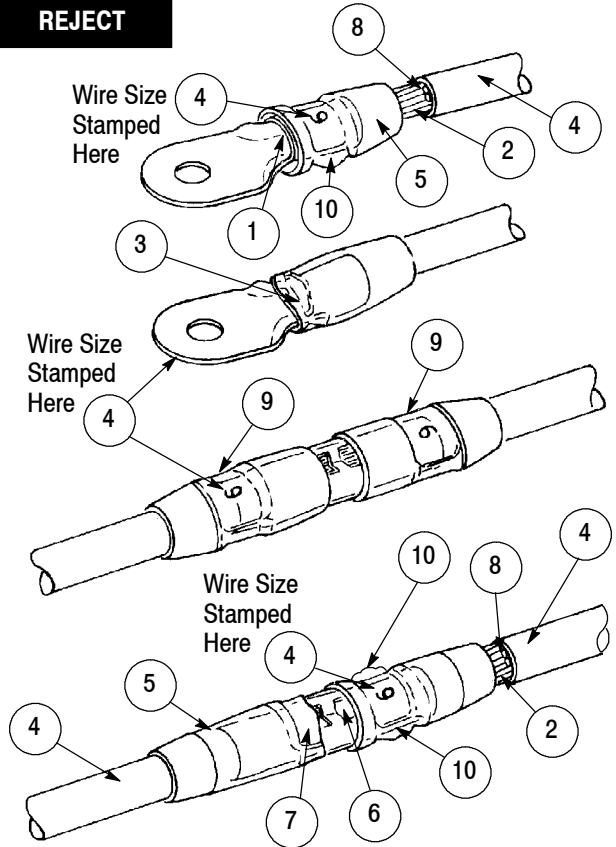

- ① End of wire conductor not flush with or extending slightly beyond end of terminal wire barrel.
- ② Wire not inserted fully or wrong strip length used.
- ③ Crimp not centered on terminal wire barrel. Terminal wire barrel was not butted against locator when crimped.
- ④ Wire size not the same as wire size stamped on terminal tongue, splice body, and wire barrel.
- ⑤ Wrong color code, wire size, and tooling combination used.
- ⑥ End of wire conductor not visible. Conductor did not butt against wire stop, or was not flush with or extended slightly beyond splice wire barrel.
- ⑦ Crimp not centered on splice wire barrel. Edge of window indent did not butt against locator when crimped.
- ⑧ Nicked or missing wire strands.
- ⑨ Splice was reversed in die (locator was not oriented with window indent) when crimped.
- ⑩ Excessive "flash" or extruded wire insulation (die was either damaged or incompatible when crimped).

Figure 7

9. To crimp the other half of butt splice, reposition uncrimped end of splice in the stationary die and follow the same procedure used to crimp the first half of splice.

**NOTE** *Be sure to re-assemble locator onto stationary die after crimping PLASTI-GRIP butt splices.*

10. Inspect the crimp according to Section 5.

**5. CRIMP INSPECTION**

Inspect crimped terminals and splices by checking the features described in Figure 7. Use only the terminals and splices that meet the conditions shown in the “ACCEPT” column.

**6. MAINTENANCE/INSPECTION**

**DANGER** *To avoid personal injury, always remove the battery from the tool before performing maintenance or inspection procedures.*

Each crimping die is thoroughly inspected before packaging. Since there is a possibility of damage during shipment, the crimping die should be inspected immediately upon arrival at your facility.

Regular inspections should be performed by quality control personnel. A record of scheduled inspections should remain with the dies and/or be supplied to supervisory personnel responsible for the dies. Though recommendations call for at least one inspection a month, the inspection frequency should be based on the amount of use, ambient working conditions, operator training and skill, and established company standards.

**6.1. Daily Maintenance**

It is recommended that each operator of the dies be made aware of—and responsible for—the following steps of daily maintenance:

1. Remove dust, dirt, and other contaminants with a clean brush, or a soft, lint-free cloth. Do NOT use objects that could damage the dies.
2. Make certain the dies are protected with a THIN coat of any good SAE 20 motor oil. Do not oil excessively.
3. When the dies are not in use, mate them and store in a clean, dry area.

**6.2. Visual Inspection**

1. Remove all lubrication and accumulated film by immersing the dies in a suitable commercial degreaser that will not affect paint or plastic material.
2. Make sure all die components are in place. If replacements are necessary, refer to the replacement parts listed in Figure 10.

3. Check components for wear. Remove and replace worn components.

4. Inspect the crimp area for flattened, chipped, cracked, worn, or broken areas. If damage is evident, the dies must be repaired before returning them to service (see Section 7, REPLACEMENT AND REPAIR).

**6.3. Gaging the Crimping Chamber**

The die closure inspection is accomplished using plug gages. A suggested gage design and the GO and NO-GO diameters of the plug gage elements are shown in Figure 8. The following procedure is recommended for inspecting the die closures.

1. Mate the dies until it is evident that they have bottomed. Hold the dies in this position.

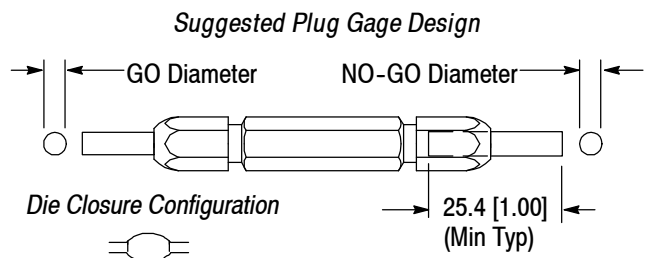

| CRIMPING DIE | GAGE ELEMENT DIAMETER        |                              |
|--------------|------------------------------|------------------------------|
|              | GO                           | NO-GO                        |
| 1901006-1    | 5.105-5.113<br>[.2010-.2013] | 5.255-5.258<br>[.2069-.2070] |
| 1901007-1    | 6.020-6.027<br>[.2370-.2373] | 6.170-6.172<br>[.2429-.2430] |

Figure 8

2. Align the GO element with the crimping chamber. Push element straight into the crimping chamber without using force. The GO element must pass completely through the crimping chamber as shown in Figure 9.
3. Align the NO-GO element and try to insert it straight into the crimping chamber. The NO-GO element may start entry but must not pass completely through as shown in Figure 9.

If the crimping chamber conforms to the gage inspection, the crimping die is considered dimensionally correct and should be lubricated with a THIN coat of SAE 20 motor oil. If not, the dies must be repaired before returning them to service (see Section 7, REPLACEMENT AND REPAIR).

For additional information concerning the use of a plug gage, refer to Instruction Sheet 408-7424.

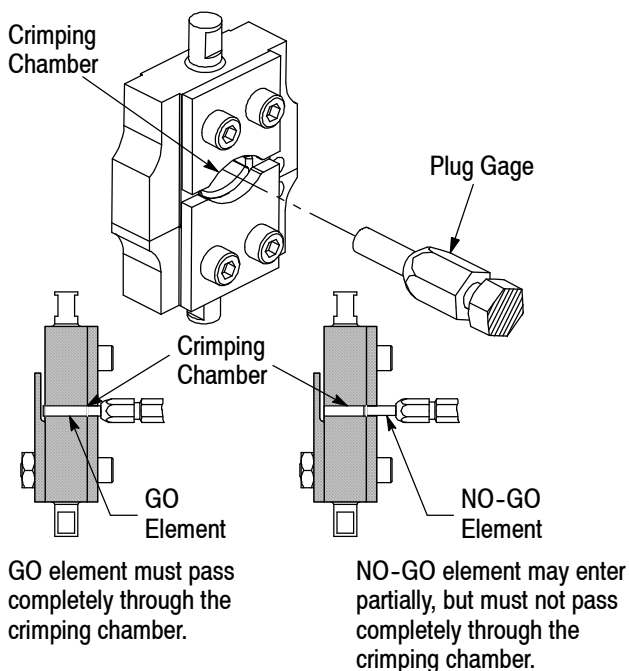

Figure 9

## 7. REPLACEMENT AND REPAIR

The parts listed in Figure 10 are customer-replaceable. A complete inventory can be stocked and controlled to prevent lost time when replacement of parts is necessary. Order replacement parts through your TE Connectivity Representative, or call 1-800-526-5142, or send a facsimile of your purchase order to 1-717-986-7605, or write to:

CUSTOMER SERVICE (38-35)  
 TYCO ELECTRONICS CORPORATION  
 P.O. BOX 3608  
 HARRISBURG, PA 17105-3608

Dies may be returned for evaluation and repair. For die repair service, contact a TE Representative at 1-800-526-5136.

## 8. REVISION SUMMARY

- Added new text to Section 1
- New logo

1901006-1

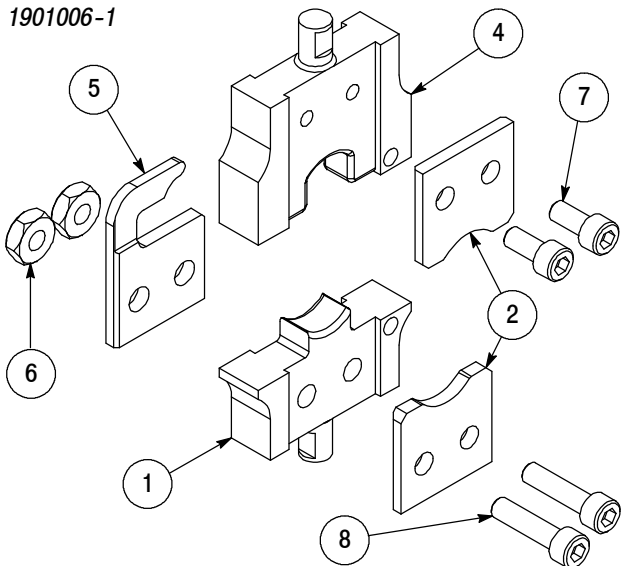

1901007-1

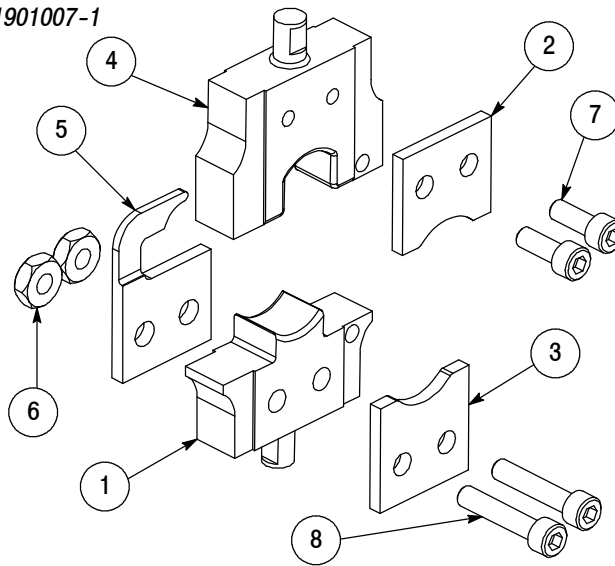

| ITEM NO. | CRIMP DIE PART NUMBER |            | DESCRIPTION            | QTY PER ASSY (1901006-1) | QTY PER ASSY (1901007-1) |
|----------|-----------------------|------------|------------------------|--------------------------|--------------------------|
|          | 1901006-1             | 1901007-1  |                        |                          |                          |
| 1        | 1901015-2             | 1901015-1  | ANVIL                  | 1                        | 1                        |
| 2        | 1901004-2             | 1901004-1  | FLARE PLATE            | 2                        | 1                        |
| 3        | ---                   | 1901004-3  | FLARE PLATE            | ---                      | 1                        |
| 4        | 1901016-2             | 1901016-1  | INDENTER               | 1                        | 1                        |
| 5        | 1901003-2             | 1901003-1  | LOCATOR                | 1                        | 1                        |
| 6        | 21018-5               | 21018-5    | NUT, Hex, Reg 6-32     | 2                        | 2                        |
| 7        | 8-21000-8             | 1-21000-9  | SCREW, Skt Hd Cap 6-32 | 2                        | 2                        |
| 8        | 4-306105-5            | 4-306105-5 | SCREW, Skt Hd Cap 6-32 | 2                        | 2                        |

Figure 10